

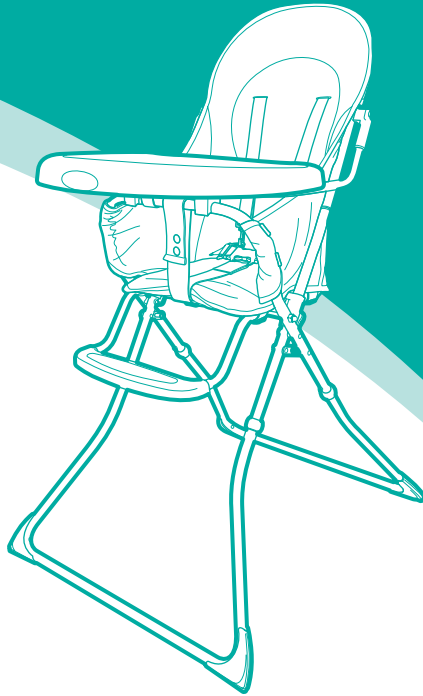

MY CHILD[®]

Pepper Highchair Instruction manual



IMPORTANT! READ CAREFULLY AND KEEP FOR FUTURE REFERENCE

Suitable for children who can sit up unaided, aged approximately 6 months to 3 years but not exceeding 15kg.

Your child's safety may be affected if you do not follow these instructions.

EN14988:2017+A1:2020 / EN16120:2012+A2:2016

Safety instructions

We know that safety is of utmost concern for parents and carers of children. Whilst this product has been developed to all of the relevant safety standards, we need your help to maintain that level of safety and minimise the risk of a baby using this product being harmed. Your baby should never be left alone in the highchair and all harmful objects should be kept out of your child's reach.

Warning: NEVER leave the child unattended.

Warning: Always use the restraint system.

Warning: Falling hazard: Prevent your child from climbing on the product.

Warning: Do not use the product unless all components are correctly fitted and adjusted. Your child's safety is your responsibility.

Warning: Be aware of the risk of open fires and other sources of strong heat, such as electric bar fires, gas fires etc. in the vicinity of the product.

Warning: To avoid injury keep your child away when folding and unfolding this product.

Warning: Be aware of the risk of tilting when your child can push its feet against a table or any other structure.

- Ensure that the locks and catches on the product are not obstructed at any time during use.
- Do not let your child play with this product.
- Ensure the safety harness is fastened and correctly adjusted at all times.
- Do not use near stairs or steps.
- Ensure the highchair is used on a secure and level surface.
- Never carry the highchair with your baby in it.
- Do not use if any part is broken, torn or missing. Periodically check for loose or damaged parts.
- Only for use by children who can sit up and support themselves unaided.
- Only use parts and accessories approved by the manufacturer. Others may render the highchair unsafe and will invalidate the warranty.
- This highchair is designed to hold 1 child.

Your 3 year warranty

Whilst we make and test our products to the highest standards of durability there's always a small chance of a hiccup! Our promise is to repair, replace or refund a MyChild product that has an identified manufacturing defect from the date of purchase for a full 3 years thereafter at no extra cost.

However, you must register within 28 days of the date of purchase to receive the full 3 years guarantee!

To receive your full guarantee you can register your product by: visiting www.mychild.co.uk/warranty.html and complete the warranty form, or by telephone on 0161 335 2508.

Welcome

Thank you for purchasing the MyChild Pepper Highchair.
Please read the instructions and warnings carefully before use to ensure safe and satisfactory operation of this product.

Your child's safety is your responsibility. If you have a query with this product or require replacement parts, please contact the MyChild Helpline on 0161 335 2508.

Lay out the parts on a soft level surface and compare to the part/fixings checklist below. Do not discard any packaging until you are sure that you have all the parts.

WARNING! Assembly by an adult. Keep away from children until fully assembled. Keep children clear during assembly as pack contains small parts which may present a choking hazard.

Parts checklist

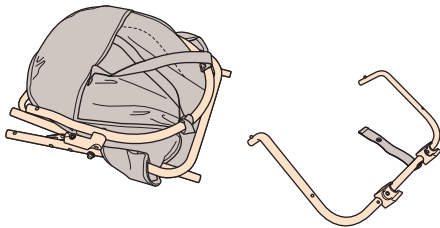

1

2

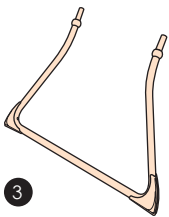

3

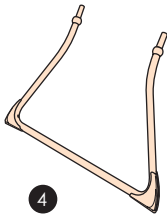

4

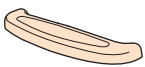

5



6

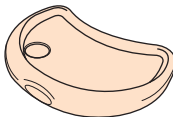

7



8



9

Contained in your carton are:

Nº	Part	Qty
1	Seat unit	1
2	Tray frame tubing	1
3	Rear leg tubing*	1
4	Front leg tubing**	1
5	Footrest	1
6	Feet	4
7	Tray	1
8	Plastic spacers	2
9	Screws	12

* Slightly wider than front leg tubing

** Slightly narrower than rear leg tubing

You will require one Phillips screwdriver (not supplied).



Assembling the seat unit backrest

1. Open the seat unit.

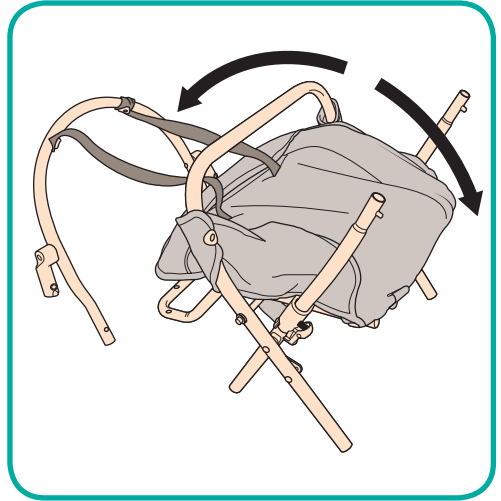

2. Ensure the backrest tubing (A) is at the back of the highchair. If it is not, then, feed the backrest tubing (A) all the way under the front bar (B) and out so that it is at the back of the highchair.

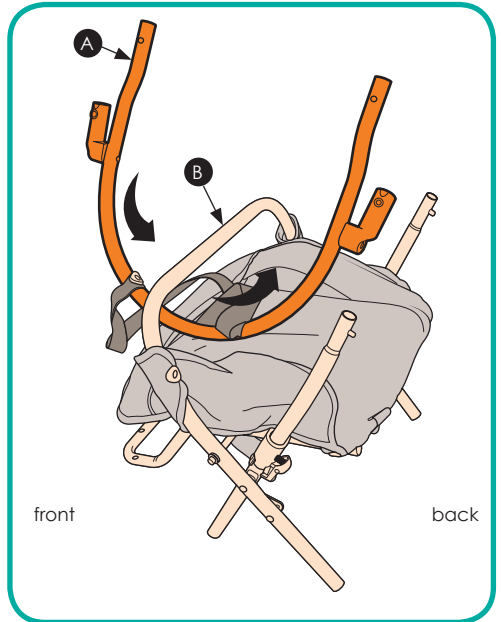

Assembling the seat unit backrest (continued)

3. Pull the backrest seat cover from under the front bar (C) as shown.

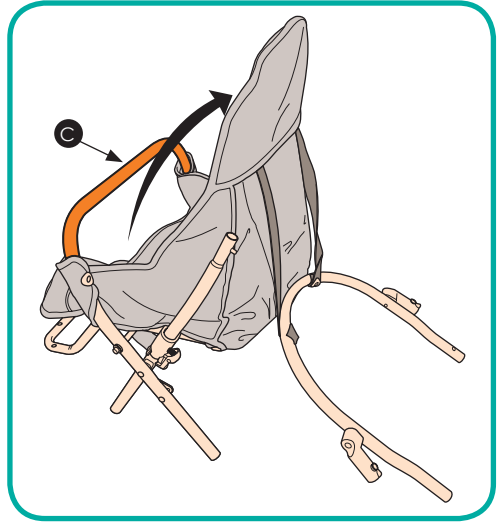

4. Press the release latches on both sides (D) and at the same time fold the seat together.

IMPORTANT! The seat must be folded together for the following two steps.

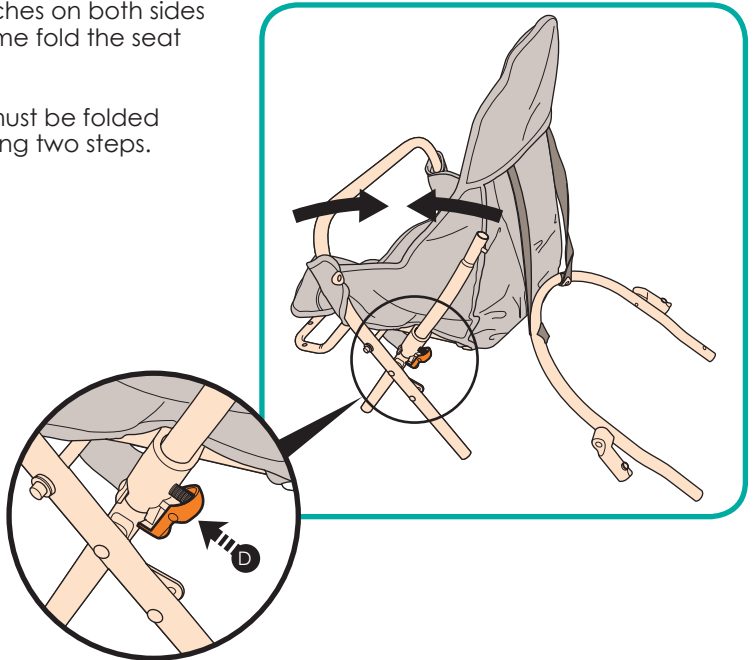

Assembling the seat unit backrest (continued)

5. With the seat folded, feed the backrest tubing (E) into the pocket on the backrest cover, ensuring the two shoulder straps (F) are not twisted around one another.

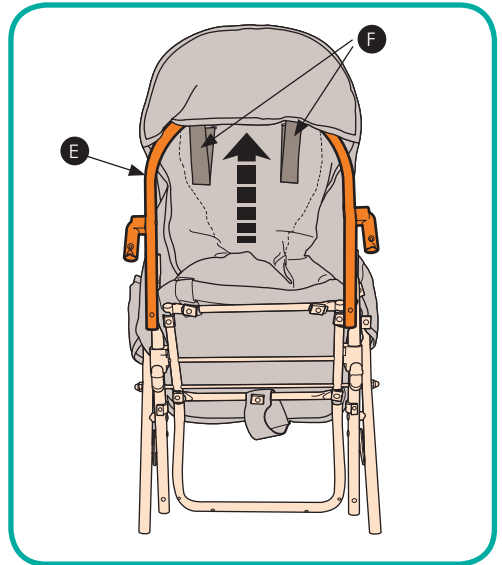

6. Place the two ends of the backrest frame (G) onto the two ends of the seat base frame (H) ensuring both spring pins click into place.

Top Tip: Angle the backrest frame (G) slightly towards the front of the highchair as you begin connecting the tubing.

IMPORTANT: The backrest frame will not fit onto the seat base frame if the highchair is unfolded.

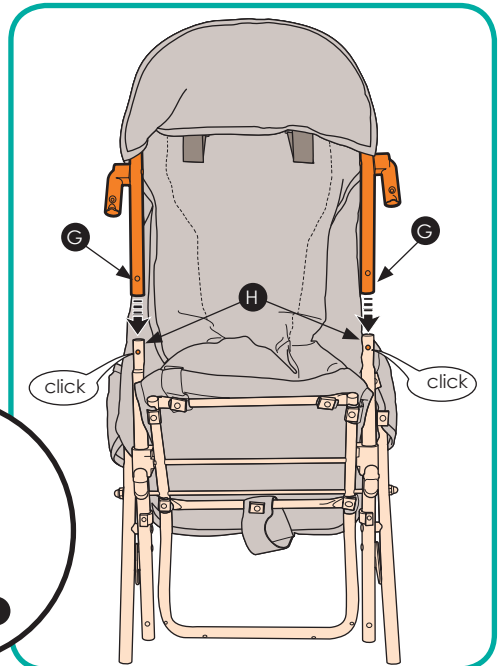
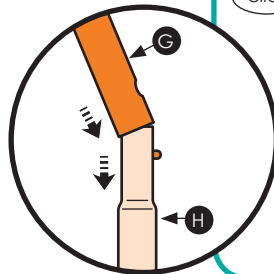

Attaching the tray

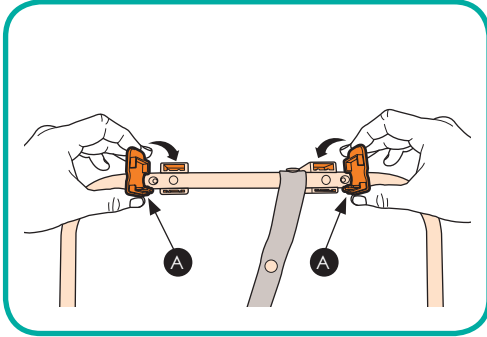

1. Slot the two plastic spacers (A) over the two plastic parts on the tray frame.

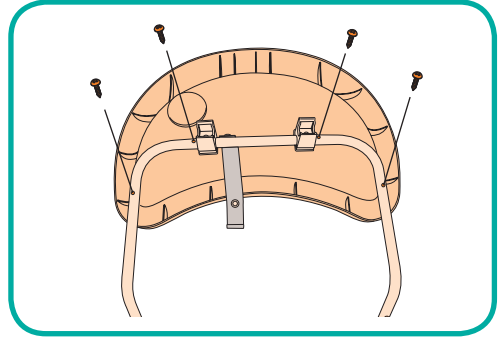

2. With the tray turned upside down place the tray frame (complete with spacers) onto the tray as shown. Secure the tray to the tray frame using four screws.

IMPORTANT: DO NOT overtighten the screws.

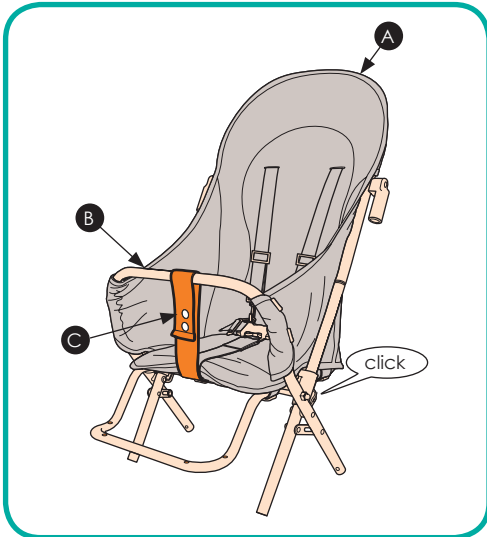

3. Holding the back of the seat frame (A) and the front bar (B), open the seat unit out ensuring it clicks into place.

Wrap the seat strap (C) over the front bar (B) and fasten the two press studs.

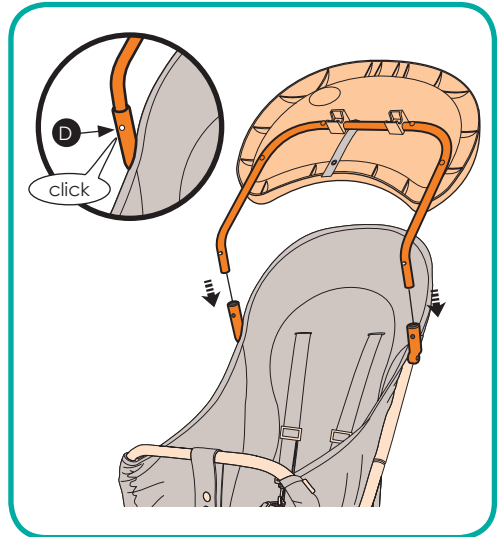

4. Push the two ends of the tray frame into the attachment points on each side of the seat unit, ensuring the spring pins (D) click into place.

Attaching the tray (continued)



5. Push the tray down onto the front bar ensuring it clicks into place and secure the tray using press stud and strap (E).

Attaching the footrest

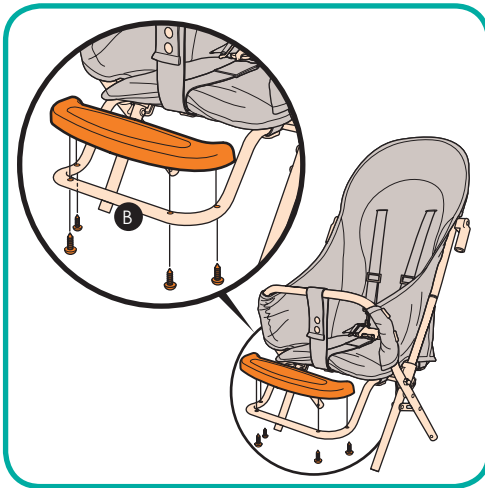

1. Attach the footrest (A) to the footrest bar (B) using four screws

IMPORTANT: DO NOT overtighten the screws.

Attaching the legs

Keep fingers clear of all potential pinch points during assembly.

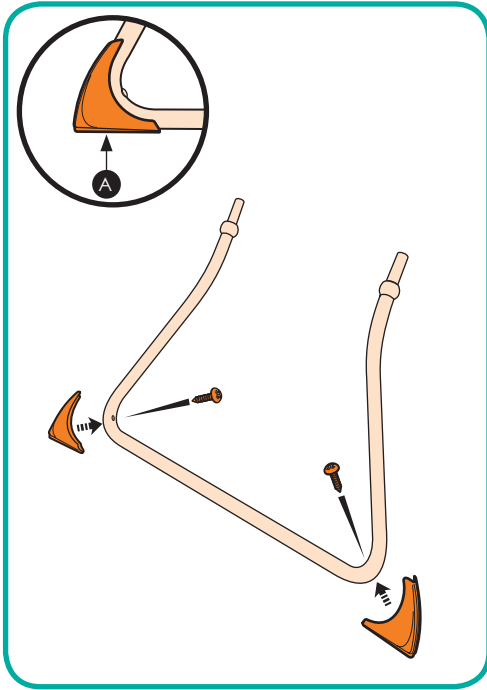

1. Attach the feet to the front and rear leg tubing, ensuring the straight edge (A) on each foot goes against the floor. Secure each foot using one screw.

IMPORTANT: DO NOT overtighten the screws.

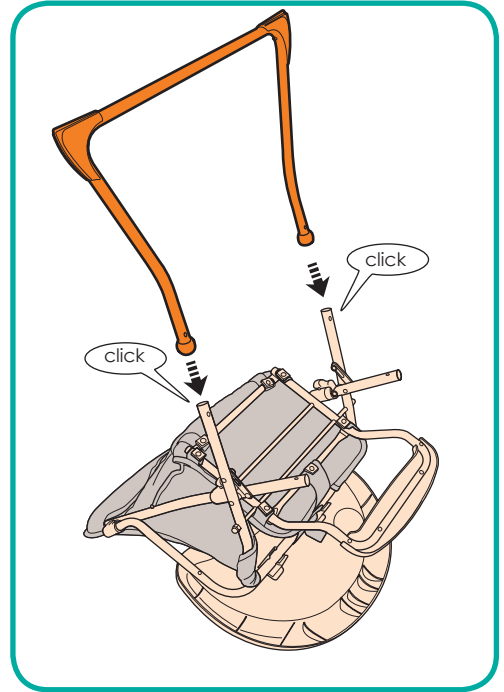

2. Place the seat unit upside down on the floor.

Insert the rear leg tubing (the wider of the two sets of leg tubing) into the back legs of the seat unit. Press in the spring pins and push the leg tubing in till the spring pins click into place.

Repeat the above steps for fitting the front legs.

Unfolding the highchair

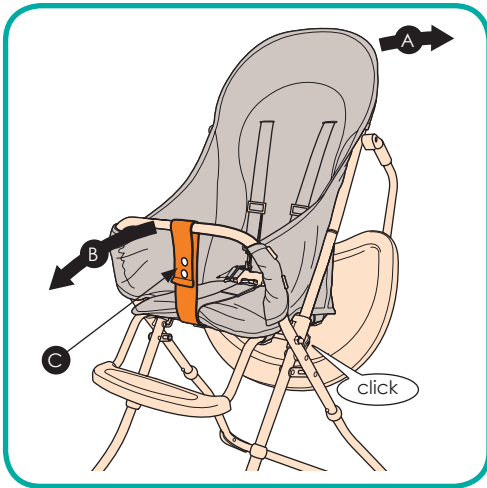

1. Holding the back of the seat frame (A) and the front bar (B), open the seat unit out, ensuring it clicks into place.

Wrap strap (C) over the front bar (B) and fasten the two press studs.

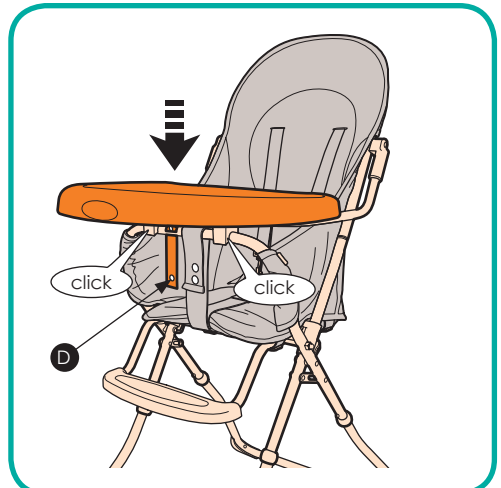

2. Push the tray down onto the front bar ensuring it clicks into place and secure the tray using press stud and strap (D).

Placing your child in the highchair

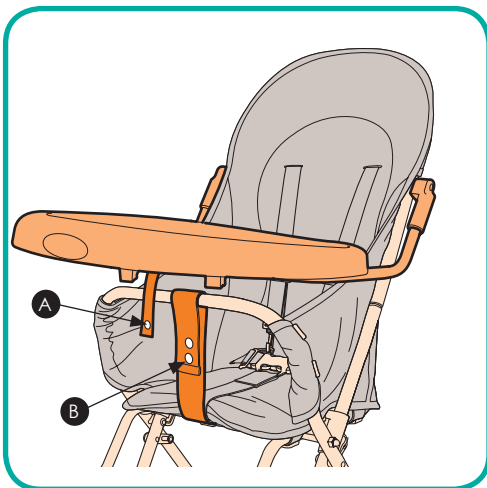

1. Before placing your child in the highchair ensure the seat strap (B) is securely fastened.

If it is not fastened:

1. Release tray strap (A).
2. Lift up the tray.
3. Wrap the seat strap (B) around the front bar and secure using the press studs.
4. Replace the tray, making sure that it clicks into place.
5. Fasten the tray strap (A) using the press stud.

WARNING: Do not use the highchair without the seat strap being secured. The seat strap provides secondary protection against accidental sliding out and folding of the highchair.

Placing your child in the highchair (continued)

The highchair should only be used with the feeding tray in place. It is essential that the five-point harness is used at all times. When using the highchair at a table ensure the child cannot push against the table or any other surface as this could result in the highchair tipping over.

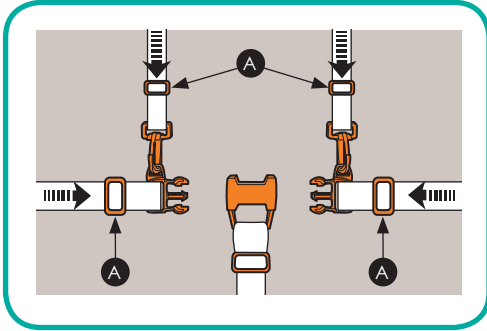

2. Fastening the 5-point harness:

To secure your child in the harness, place the crotch strap between your child's legs and insert the harness clips into the buckle, making certain your child's fingers are clear. Adjust the sliders (A) on the waist and shoulder straps so that the harness fits snugly.

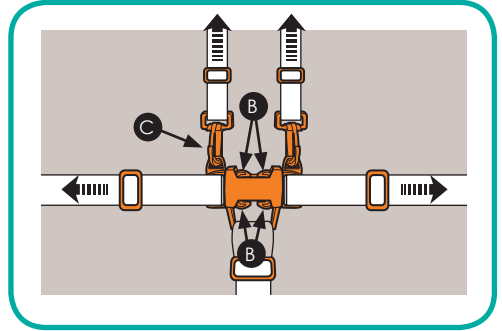

3. Releasing the 5-point harness:

Using your thumb and forefinger, squeeze the top and bottom of the waist strap connector (B). The shoulder straps can be unclipped from the waist straps if necessary (C).

Folding the highchair

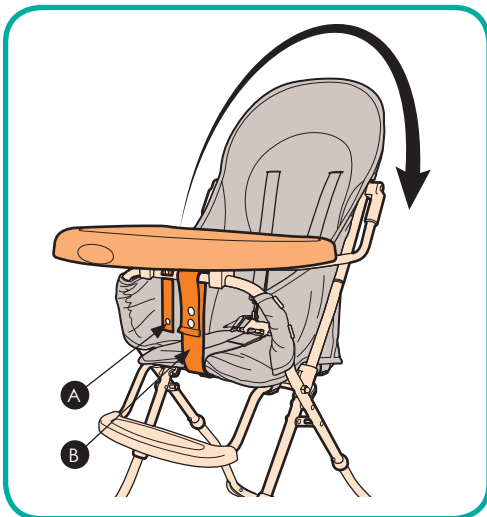

1. Unfasten the tray strap (A) and seat strap (B).

Hold on to the back of the chair and pull the tray upwards to release it. Rotate the tray over the seat back allowing it to hang down behind the seat unit.

Folding the highchair (continued)

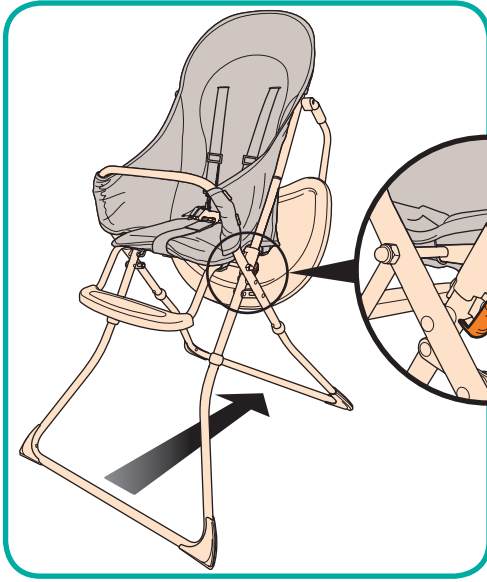

2. Standing behind the highchair press the release latches on both sides (C) and at the same time, pull the front legs towards you folding the highchair.

Dismantling for travel

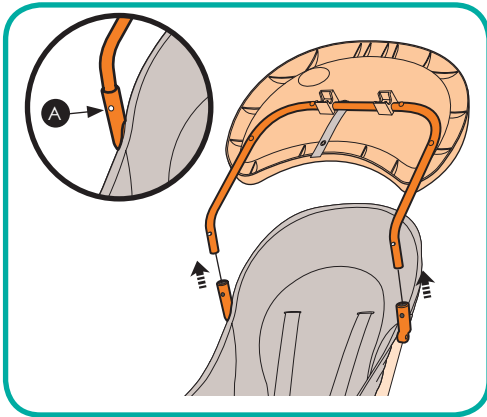

1. Removing the main tray:

Press in the spring pins (A) on the underside of the tray frame and at the same time pull the tray free from the highchair.

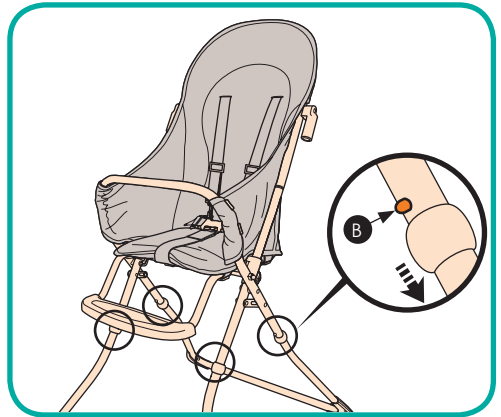

2. Removing the legs:

Press in the spring pins (B) on the inside of the legs and at the same time pull the legs free from the highchair seat unit.

You can now fold the seat unit as normal and transport (or store) the highchair more easily.

Removing the harness

The 5-point harness can be removed for washing or replacing.
The harness should be washed by hand at 30°C using a mild detergent.
Do NOT tumble dry. Air dry only.

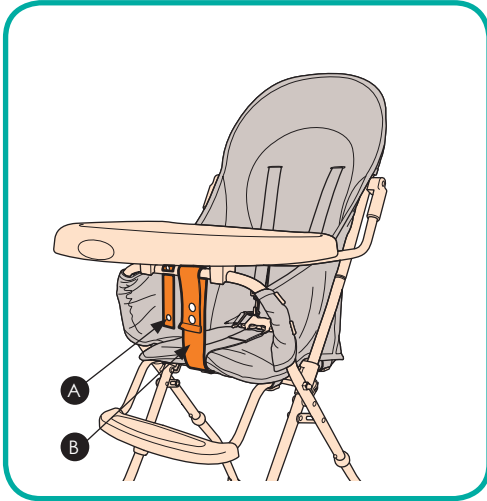

1. Unfasten the tray strap (A) and seat strap (B).

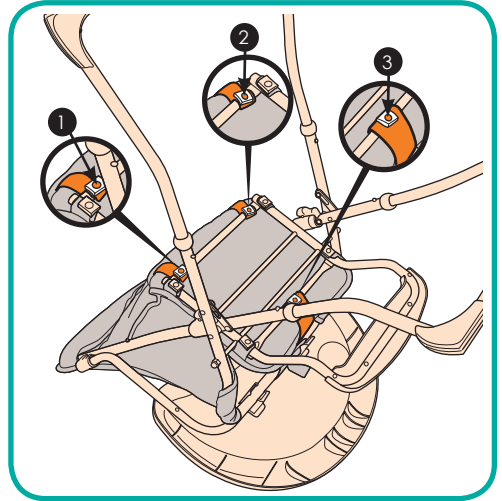

2. Turn the highchair upside down and unscrew screws (1, 2 & 3) using a phillips screwdriver.



3. Stand the highchair the right way up and fold the tray over the back of the seat.

Removing the harness (continued)

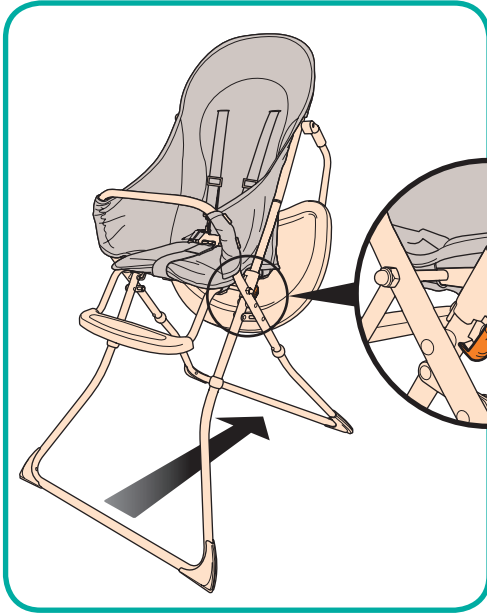

4. Standing behind the highchair press the release latches on both sides (C) and at the same time, pull the front legs towards you folding the highchair.

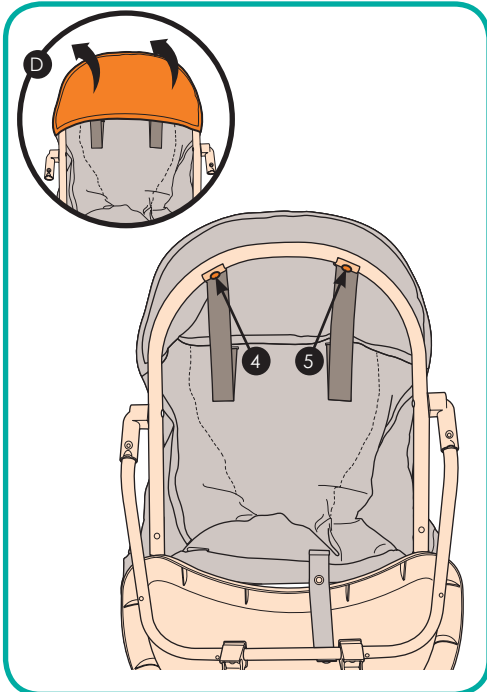

5. Slide the top of the seat fabric off the seatback (D) to expose the shoulder strap fixing points and unscrew screws (4 & 5) using a phillips screwdriver.

To reattach or replace the harness reverse steps 1 to 5.

Care and maintenance

- Avoid placing the highchair in direct sunlight for extended periods. Over time this will cause fabrics and paints to fade.
- The 5-point harness can be removed and hand washed at 30°C using a mild detergent. Do NOT tumble dry. Air dry only. See pages 10-12 for removing the harness.
- Clean the seat fabric using either a dry or damp cloth. Do not soak the seat fabric or attempt to wash by hand or by machine.
- DO NOT Iron or expose the seat fabric to strong heat.
- The feeding tray can be wiped clean using a damp cloth and mild disinfectant.
- The highchair frame can be cleaned using a damp-wet cloth with warm water and a mild detergent.
- A mild disinfectant can be used if desired. Stubborn marks maybe removed with a NON-abrasive cleaner.
- The highchair must be dried thoroughly before using or storing.
- NEVER clean any part of the highchair with abrasive, ammonia based, bleach based or spirit type cleaners.
- Apply a small amount of light lubricant such as WD40 to any of the moving parts of the highchair as required, but be careful not to get any on the fabric as it may stain, wipe off any excess lubricant.



www.mychild.co.uk

Customerservice@kooltrade.co.uk
Imported by Kooltrade Ltd. M34 3QA
Tel: 0161 335 2508